

## PZ 1740E / PZ 1660E Single-Color Press

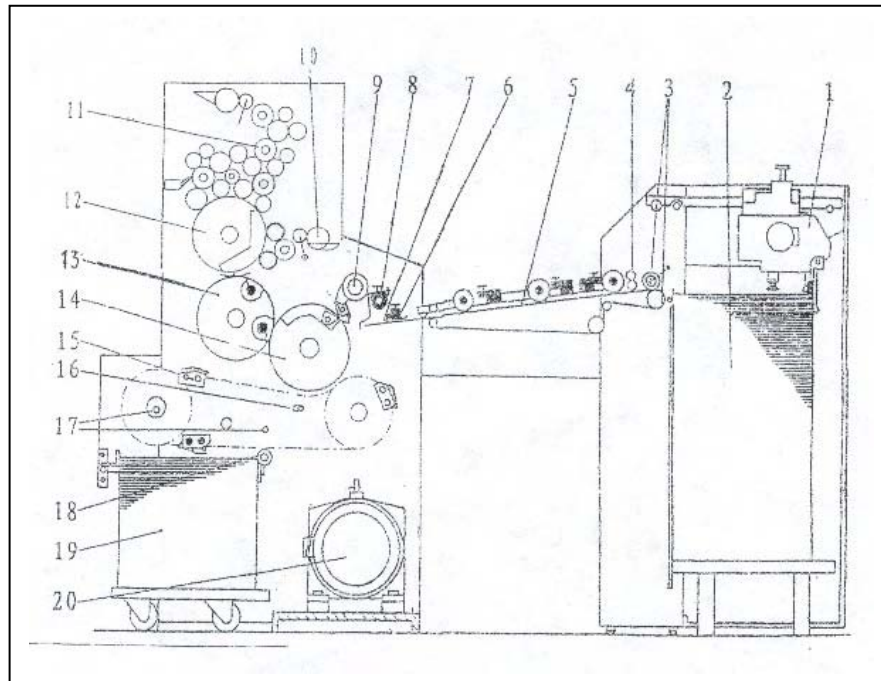

- |                                       |                          |
|---------------------------------------|--------------------------|
| 1. Feeder head                        | 11. Inking System        |
| 2. Feeder pile                        | 12. Plate cylinder       |
| 3. Tape drive shaft/forwarding roller | 13. Blanket cylinder     |
| 4. Double sheet detector              | 14. Impression cylinder  |
| 5. Feed table                         | 15. Delivery gripper bar |
| 6. Pull lay                           | 16. Powder spray device  |
| 7. Electric eye sheet detector        | 17. Blast air pipe       |
| 8. Front lay                          | 18. Vacuum sheet brake   |
| 9. Transfer gripper                   | 19. Delivery pile        |
| 10. Dampening System                  | 20. Motor                |